





MAX. MOVEMENTS/H	10
AVERAGE GATE SPEED	0,082 m/s
MOTOR UTILIZATION	81 %

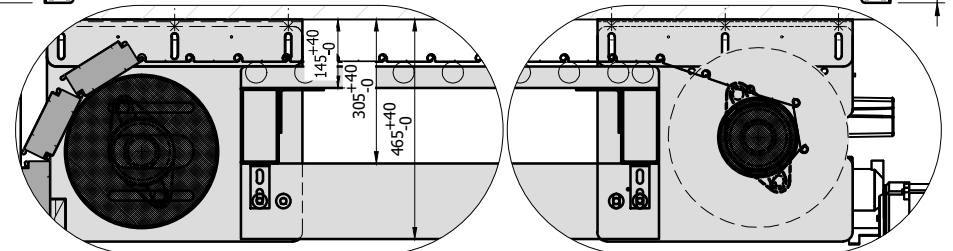
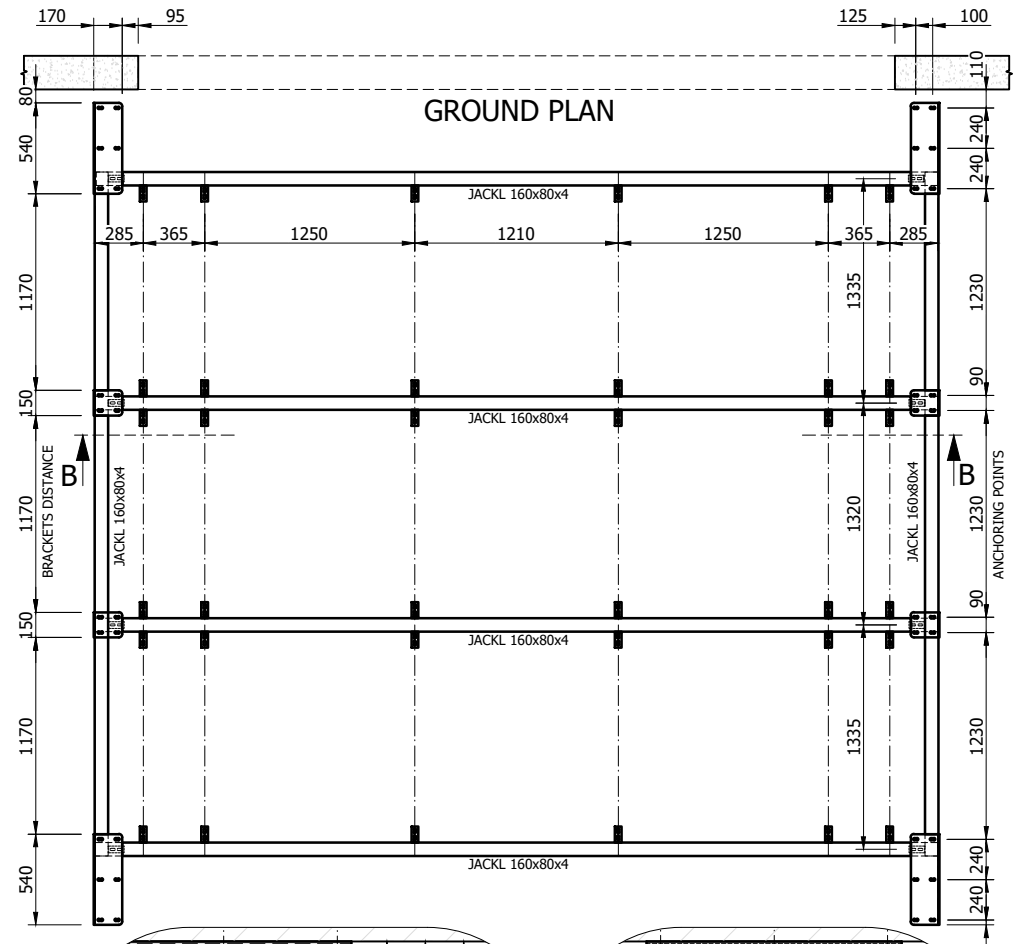
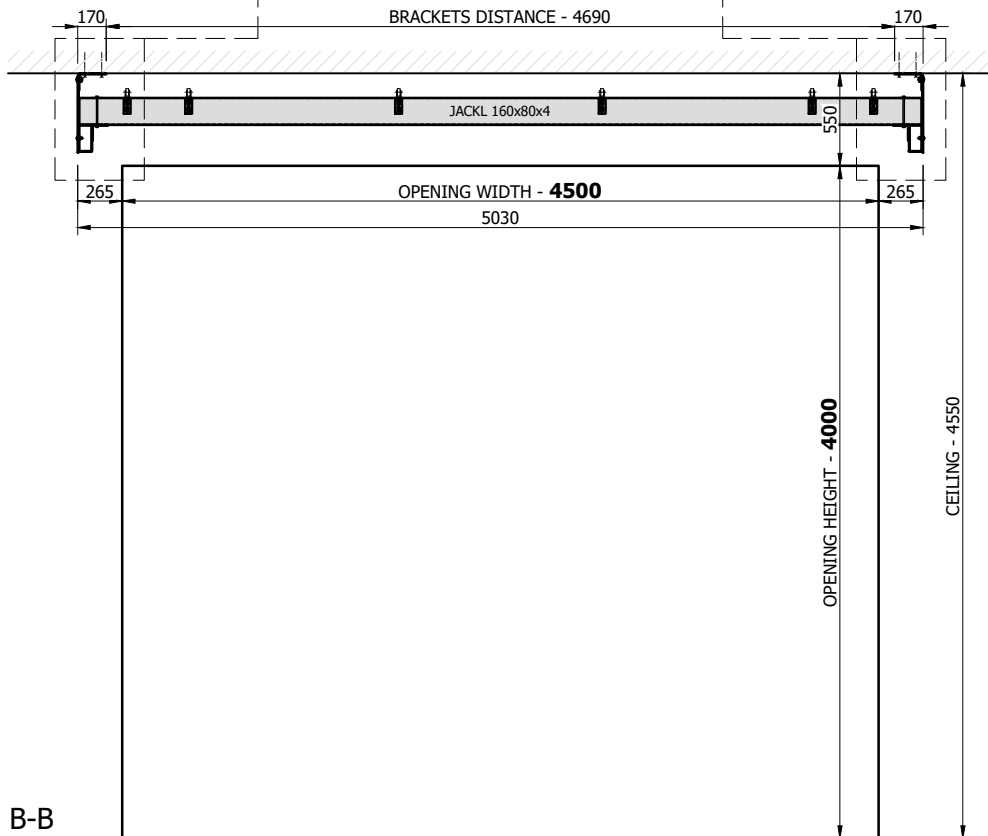
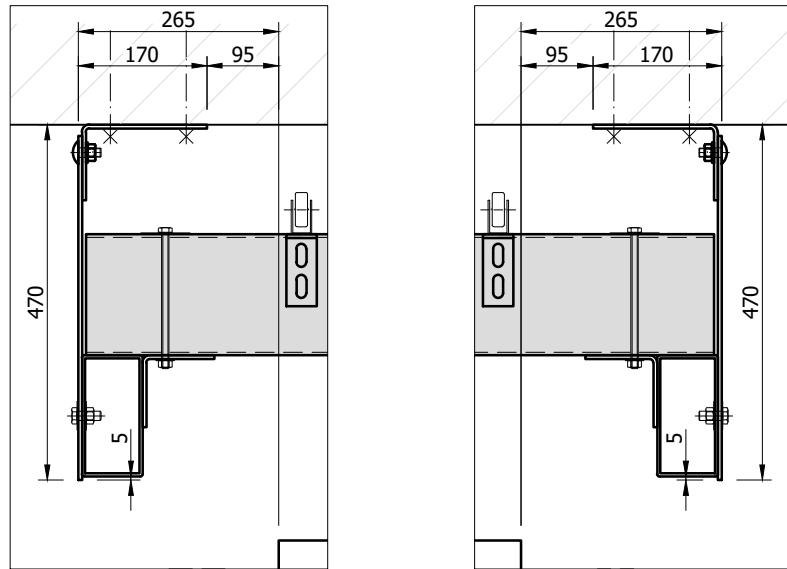

Top coat: **GALVANIZED**

SERIAL NR.	212xxxx	TYPE	RGS-120-H	FIRE RESISTANCE	EI₂ 120-C			
ORDER NR.	SE-1119	PROJECT						
PRICE OFFER NR.	SE-1119	CUSTOMER	T-Center Sverige AB					
ITEM	01	DRAWING	01.00	RGS-120-H 4,50 x 4,00 m				
DATE	DRAWN BY	GEOMETRICAL TOLERANCES	PROJECTION [ISO E]	SCALE	PCS	WEIGHT [kg]	MATERIAL SEMI PRODUCT	 BRANDPORTAR SWEDEN Industrial Firedoor Solutions
10.11.2021	PAVY	ISO 2768-mL		1:45 1:8	1	2480	---	

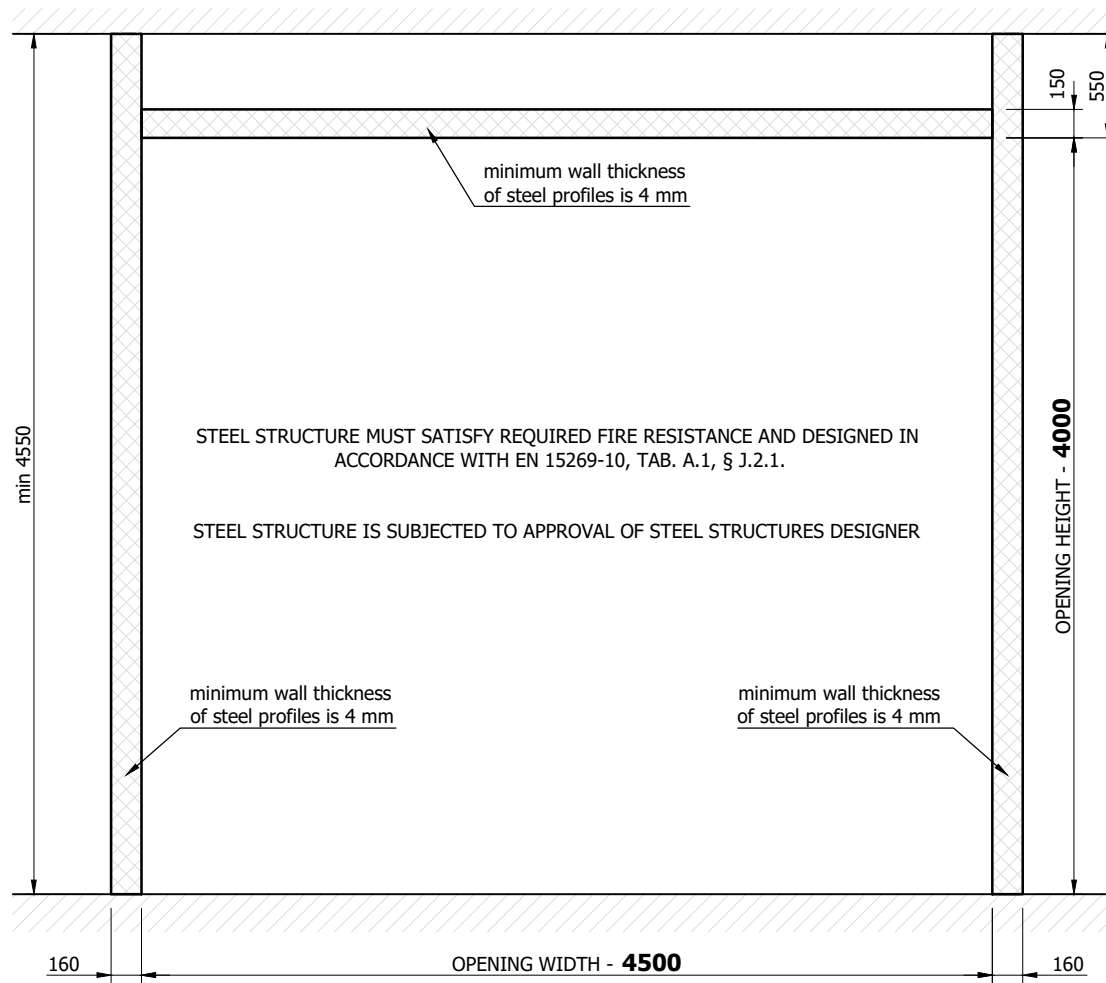

SERIAL NR.	212xxxx	TYPE	RGS-120-H	FIRE RESISTANCE	EI₂ 120-C			
ORDER NR.	SE-1119	PROJECT						
PRICE OFFER NR.	SE-1119	CUSTOMER	T-Center Sverige AB					
ITEM	01	DRAWING	01.01	HORIZONTAL STEEL STRUCTURE				
DATE	DRAWN BY	GEOMETRICAL TOLERANCES	PROJECTION [ISO E]	SCALE	PCS	WEIGHT [kg]	MATERIAL SEMI PRODUCT	 BRANDPORTAR SWEDEN Industrial Firedoor Solutions
10.11.2021	PAVY	ISO 2768-mL		1:45 1:16, 1:10	-	---	---	



SERIAL NR.	212xxxx		TYPE	RGS-120-H		FIRE RESISTANCE	EI₂ 120-C	
ORDER NR.	SE-1119		PROJECT					
PRICE OFFER NR.	SE-1119		CUSTOMER	T-Center Sverige AB				
ITEM	01	DRAWING	01.02	VERTICAL STEEL STRUCTURE				
DATE	DRAWN BY	GEOMETRICAL TOLERANCES	PROJECTION [ISO E]	SCALE	PCS	WEIGHT [kg]	MATERIAL SEMI PRODUCT	 BRANDPORTAR SWEDEN Industrial Firedoor Solutions
10.11.2021	PAVY	ISO 2768-mL		1:40	-	---	---	

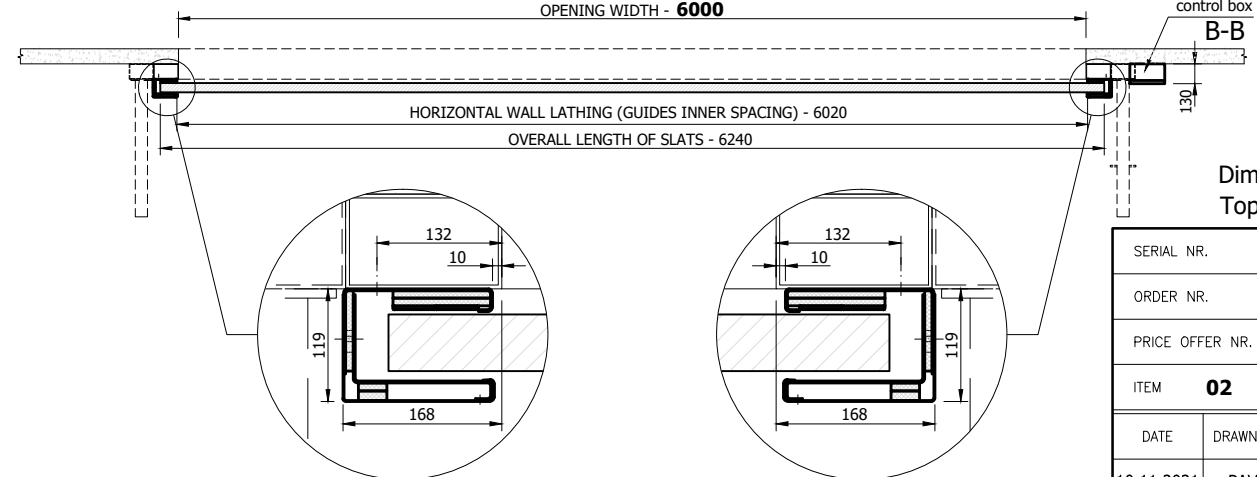
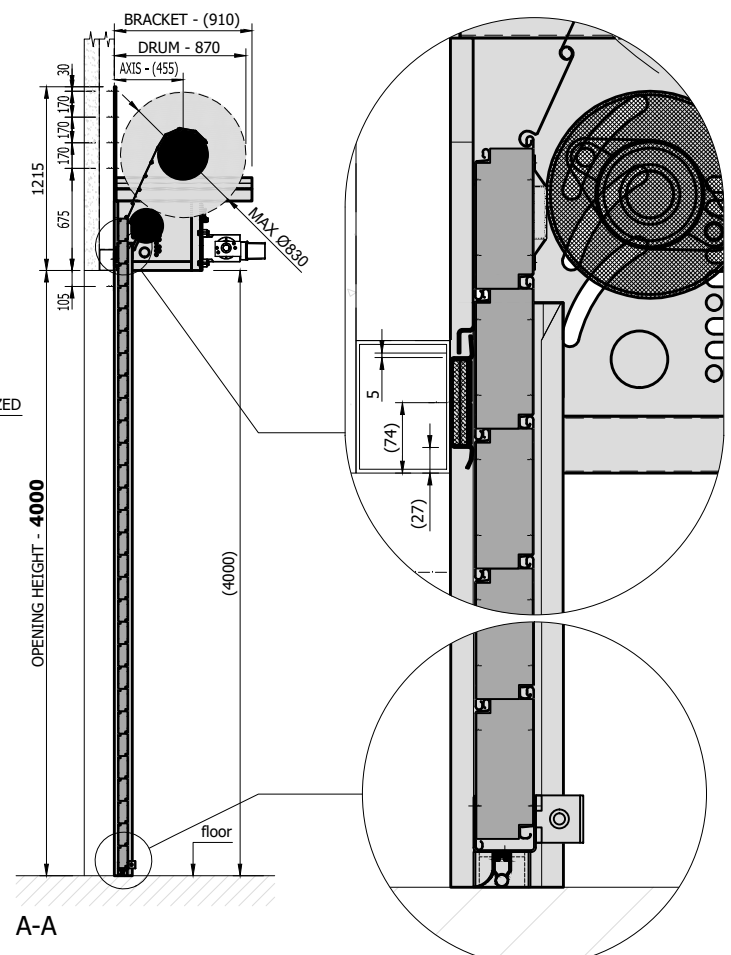
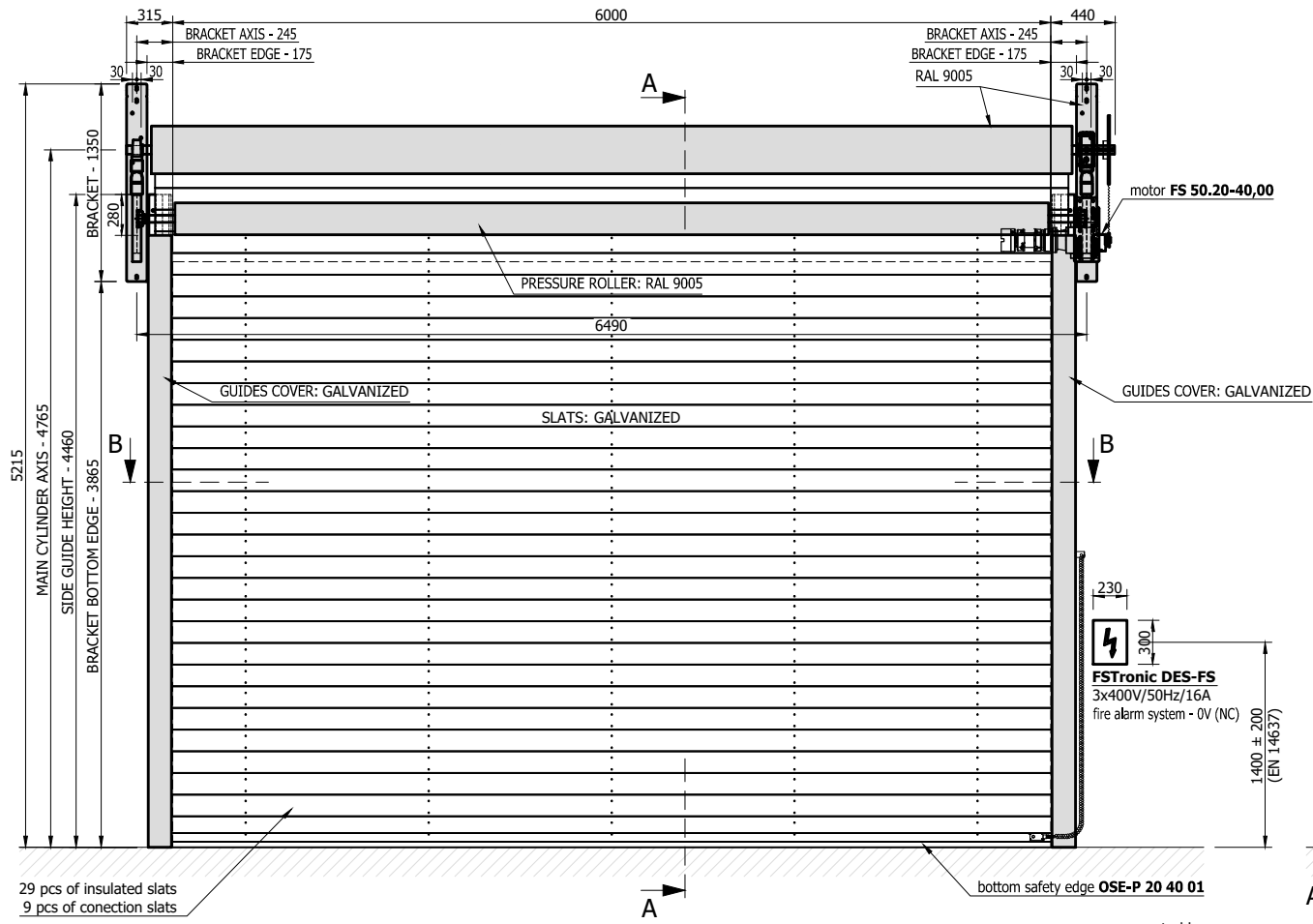



Dimensions in brackets are for reference only.
 Top coat: **ZINC COATED**

MAX. MOVEMENTS/H	12
AVERAGE GATE SPEED	0,097 m/s
MOTOR UTILIZATION	96 %

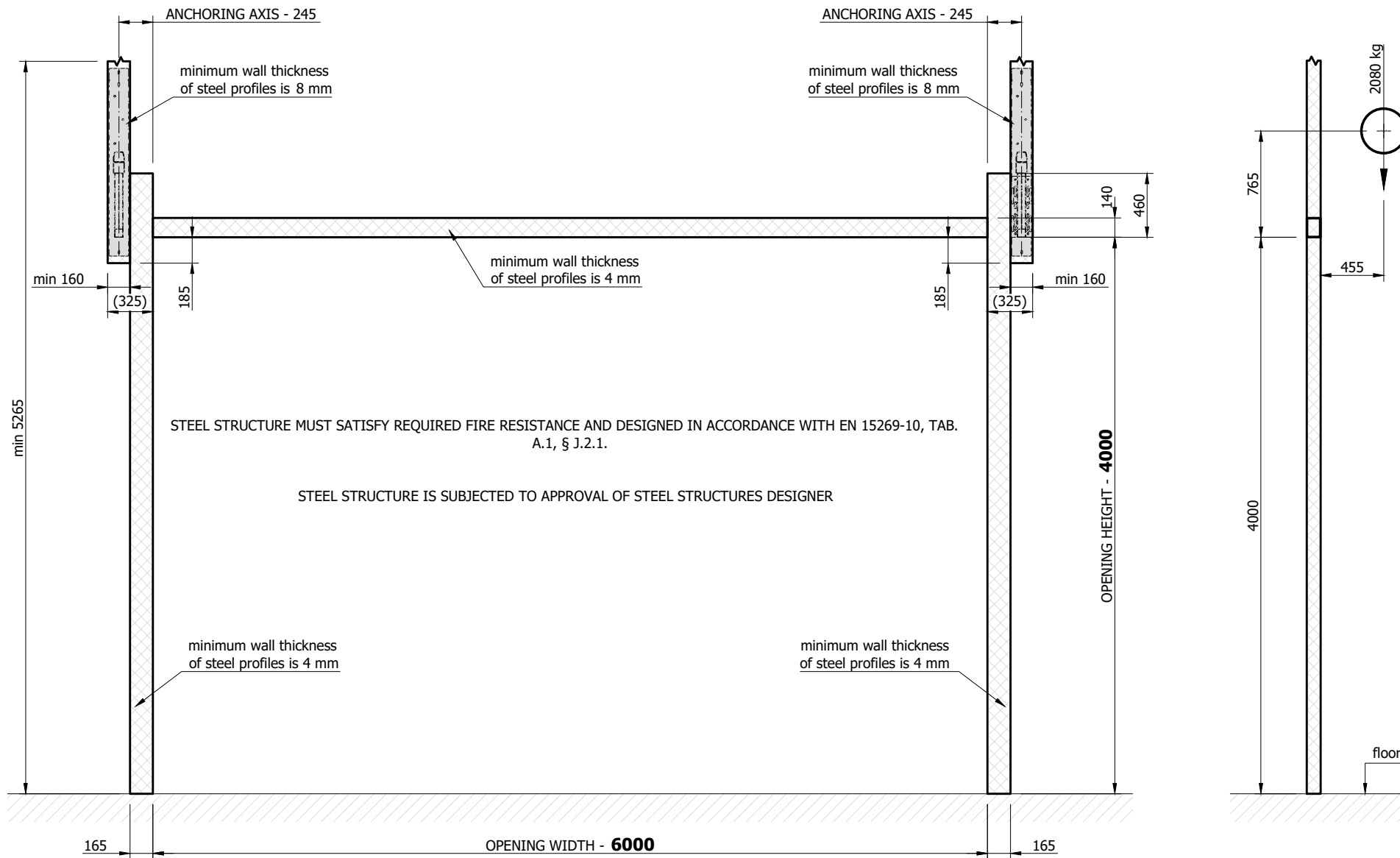
SERIAL NR.	212xxxx	TYPE	RGS-120	FIRE RESISTANCE	EI₂ 120-C			
ORDER NR.	SE-1119	PROJECT						
PRICE OFFER NR.	SE-1119	CUSTOMER	T-Center Sverige AB					
ITEM	02	DRAWING	01.00	RGS-120 6,00 x 4,00 m				
DATE	DRAWN BY	GEOMETRICAL TOLERANCES	PROJECTION [ISO E]	SCALE	PCS	WEIGHT [kg]	MATERIAL SEMI PRODUCT	BRANDPORTAR SWEDEN Industrial Firedoor Solutions
10.11.2021	PAVY	ISO 2768-mL		1:50 1:8	1	2080	---	



SERIAL NR.	212xxxx	TYPE	RGS-120	FIRE RESISTANCE	EI₂ 120-C			
ORDER NR.	SE-1119	PROJECT						
PRICE OFFER NR.	SE-1119	CUSTOMER	T-Center Sverige AB					
ITEM	02	DRAWING	01.01	Steel structure				
DATE	DRAWN BY	GEOMETRICAL TOLERANCES	PROJECTION [ISO E]	SCALE	PCS	WEIGHT [kg]	MATERIAL SEMI PRODUCT	 BRANDPORTAR SWEDEN Industrial Firedoor Solutions
10.11.2021	PAVY	ISO 2768-mL		1:40	---	---	---	